

## THE JACOBI IDENTITY FOR TANGENT CATEGORIES

by J.R.B. COCKETT and G.S.H. CRUTTWELL

**Résumé.** Une catégorie avec tangente est une catégorie équipée d'un endofoncteur ayant les propriétés abstraites du foncteur fibré tangent sur la catégorie des variétés lisses. Parmi les exemples on trouve beaucoup de contextes appropriés pour la géométrie différentielle: par exemple, certaines variétés, les  $C^\infty$ -anneaux, et les modèles de la géométrie différentielle synthétique induisent des catégories avec tangente. Rosický a montré que dans ce contexte abstrait on peut définir une loi de crochet de Lie pour les champs de vecteurs correspondants. Cet auteur a aussi donné une preuve de l'identité de Jacobi pour cette loi: toutefois sa preuve n'a jamais été publiée, elle était assez complexe, et nécessitait d'hypothèses supplémentaires sur la catégorie avec tangente.

Nous donnons ici une preuve beaucoup plus courte de l'identité de Jacobi dans ce contexte, sans aucune hypothèse supplémentaire. En outre, les techniques développées pour cette preuve, notamment l'utilisation d'un calcul graphique, pourraient être utiles pour démontrer d'autres résultats dans les catégories avec tangente.

**Abstract.** A tangent category is a category equipped with an endofunctor with abstract properties modelling those of the tangent bundle functor on the category of smooth manifolds. Examples include many settings for differential geometry; for example, convenient manifolds,  $C^\infty$ -rings, and models of synthetic differential geometry all give rise to tangent categories. Rosický showed that in this abstract setting, one can define a Lie bracket operation for the resulting vector fields. He also provided a proof of the Jacobi identity for this bracket operation; however, his proof was unpublished, quite complex, and made additional assumptions on the tangent category.

We provide a much shorter proof of the Jacobi identity in this setting that does not make any additional assumptions. Moreover, the techniques developed for the proof, namely the use of a graphical calculus, may be of use in proving other results for tangent categories.

**Keywords.** Tangent categories, Lie bracket, generalized differential geometry, synthetic differential geometry.

**Mathematics Subject Classification (2010).** 18D99, 51K10.

## 1. Introduction

Tangent categories, first developed by Rosický [8] provide an axiomatic description of the tangent bundle functor. Within this abstract framework, one is interested in determining how many properties of the ordinary tangent bundle for finite dimensional smooth manifolds hold. For example, one can define vector fields for such an abstract tangent bundle, and Rosický showed that one can define a Lie bracket for two such vector fields.

Unfortunately, however, the proof of an important identity for the Lie bracket, namely the Jacobi identity

$$[x, [y, z]] + [z, [x, y]] + [y, [z, x]] = 0$$

proved elusive. Rosický did find a very long, intricate proof (approximately 80 pages); however, the proof also made additional assumptions on the tangent category and was not published.

In this paper, we give a shorter proof of this key identity that does not make any additional assumptions on the tangent category. Most of the work involved in trying to prove the identity consists of calculations with many applications of various functors and natural transformations. Our key simplification is the use of a graphical calculus to handle these calculations. By judicious use of this graphical calculus, we are able to manipulate the complex sequence of terms in the Jacobi identity for tangent categories much more easily and thus are able to perform the necessary calculations to reduce the expression to zero.

In addition to the simplification of the proof that this paper provides, we also believe that the technique we employ in this proof (namely, the use of graphical calculus) will greatly aid further calculations in tangent categories.

## 2. Tangent categories and their Lie bracket

Rosický gave the original definition of tangent categories [8]; here, we provide a modified version of the axioms found in [2].

Throughout this paper we will be writing composition in diagrammatic order, so that  $f$  followed by  $g$  is written as  $fg$ . An **additive bundle** over an object  $M$  in a category  $\mathbb{X}$  is a commutative monoid in the slice category  $\mathbb{X}/M$ , while an **additive bundle morphism** between two such objects is the obvious notion of morphism of such objects.

**Definition 2.1.** For a category  $\mathbb{X}$ , tangent structure  $\mathbb{T} = (T, p, 0, +, \ell, c)$  on  $\mathbb{X}$  consists of the following data:

- (**tangent functor**) a functor  $T : \mathbb{X} \rightarrow \mathbb{X}$  with a natural transformation  $p : T \rightarrow I$  such that each  $p_M : T(M) \rightarrow M$  admits finite wide pullbacks along itself which are preserved by each  $T^n$ .
- (**additive bundle**) natural transformations  $+ : T_2 \rightarrow T$  (where  $T_2$  is the pullback of  $p$  over itself) and  $0 : I \rightarrow T$  making each  $p_M : TM \rightarrow M$  an additive bundle;
- (**vertical lift**) a natural transformation  $\ell : T \rightarrow T^2$  such that for each  $M$ 

$$(\ell_M, 0_M) : (p : TM \rightarrow M, +, 0) \rightarrow (Tp : T^2M \rightarrow TM, T(+), T(0))$$
 is an additive bundle morphism;
- (**canonical flip**) a natural transformation  $c : T^2 \rightarrow T^2$  such that for each  $M$ 

$$(c_M, 1) : (Tp : T^2M \rightarrow TM, T(+), T(0)) \rightarrow (p : T^2M \rightarrow TM, +, 0)$$
 is an additive bundle morphism;
- (**coherence of  $\ell$  and  $c$** )  $c^2 = 1$  (so  $c$  is a natural isomorphism),  $\ell c = \ell$ , and the following diagrams commute:

$$\begin{array}{ccccc}
 T & \xrightarrow{\ell} & T^2 & & T^3 & \xrightarrow{T(c)} & T^3 & \xrightarrow{c_T} & T^3 & & T^2 & \xrightarrow{\ell_T} & T^3 & \xrightarrow{T(c)} & T^3 \\
 \ell \downarrow & & \downarrow T(\ell) & & c_T \downarrow & & \downarrow T(c) & & \downarrow & & c \downarrow & & \downarrow c_T & & \downarrow \\
 T^2 & \xrightarrow{\ell_T} & T^3 & & T^3 & \xrightarrow{T(c)} & T^3 & \xrightarrow{c_T} & T^3 & & T^2 & \xrightarrow{T(\ell)} & T^3 & & T^3
 \end{array}$$

- (**universality of vertical lift**) defining the “derived lift”  $v : T_2M \rightarrow T^2M$  by  $v := \langle \pi_0 \ell, \pi_1 0_T \rangle T(+)$ , the following diagram is a pullback<sup>1</sup>:

$$\begin{array}{ccc}
 T_2(M) & \xrightarrow{v} & T^2(M) \\
 \pi_0 p = \pi_1 p \downarrow & & \downarrow T(p) \\
 M & \xrightarrow{0} & T(M)
 \end{array}$$

A pair  $(\mathbb{X}, \mathbb{T})$  is known as a **tangent category**.

**Example 2.2.** The category of finite dimensional smooth manifolds with their usual tangent bundle forms a tangent category.

It is useful to look at how these axioms work in this particular example. In particular, it is useful to see the local form of each of the above natural transformations. Locally on  $U$ ,  $TU \cong \mathbb{R}^n \times U$ ; we shall represent an element of this tangent bundle by the pair  $\langle v, x \rangle$ . Similarly  $T_2U = \mathbb{R}^n \times \mathbb{R}^n \times U$  and  $T^2U = \mathbb{R}^n \times \mathbb{R}^n \times \mathbb{R}^n \times U$ . The natural transformations above are given by the following equations:

- projection:  $p(\langle v, x \rangle) = x$ ;
- addition:  $+(\langle v_1, v_2, x \rangle) = \langle v_1 + v_2, x \rangle$ ;
- canonical flip:  $c(\langle d, v, w, x \rangle) = \langle d, w, v, x \rangle$ ;
- vertical lift:  $\ell(\langle v, x \rangle) = \langle v, 0, 0, x \rangle$ ;
- derived lift:  $v(\langle v_1, v_2, x \rangle) = \langle v_1, 0, v_2, x \rangle$ .

A global expression for the derived lift  $v$  is also given by

$$v(\langle v_1, v_2, x \rangle) = \left. \frac{d}{dt} \right|_{t=0} (tv_1 + v_2)$$

(see [3], pg. 55). As we shall see, the universal property of this derived lift  $v$  (that is, the final axiom for a tangent category) is essential for defining the Lie bracket of two vector fields.

<sup>1</sup>In [2] this condition is given as the requirement that  $v$  is the equalizer of  $T(p)$  and  $pp_0$ : this followed the approach in [8]. However, we now believe that the condition is more naturally expressed as a pullback.

**Example 2.3.** In any model of synthetic differential geometry, the infinitesimally linear objects form a tangent category, where  $TM = M^D$ .

Another perspective on the tangent category axioms comes from seeing where the axioms come from in this model:

- projection  $p : M^D \rightarrow M$  comes from applying  $M^{(-)}$  to  $0 : 1 \rightarrow D$ ;
- addition  $+$  :  $M^{D(2)} \rightarrow M^D$  comes from the diagonal  $\Delta : D \rightarrow D(2)$ ;
- the lift  $\ell : M^D \rightarrow (M^D)^D \cong M^{D \times D}$  comes from multiplication  $D \times D \rightarrow D$ ;
- canonical flip  $c : M^{D \times D} \rightarrow M^{D \times D}$  comes from the twist  $D \times D \rightarrow D \times D$ .

**Example 2.4.** Convenient manifolds with the kinematic tangent bundle (see [4] section 28) form a tangent category, with similar transformations as in the category of finite dimensional smooth manifolds.

**Example 2.5.** Any Cartesian differential category [1] is a tangent category, with  $T(A) = A \times A$  and  $T(f) = \langle Df, \pi_1 f \rangle$ .

**Example 2.6.** A source of examples from [8] uses the fact that if  $(\mathbb{X}, \mathbb{T})$  is a tangent category then the functors from  $\mathbb{X}$  to **set** which preserve both the wide pullbacks of  $T^n(p)$  and the pullback in the universality of the lift forms a tangent category. The tangent functor is given by  $T^*(F) := TF$ . In fact, this works for any category  $\mathbb{Y}$  in place of **set** and functors  $\mathbb{X} \rightarrow \mathbb{Y}$  which preserve the required pullbacks. This source of examples includes  $C^\infty$ -rings (see [7] chapter 1) and more generally the product preserving functors from any Cartesian differential category.

**Example 2.7.** The category of functors from any category to a tangent category  $\text{Cat}(\mathbb{C}, \mathbb{X})$  inherits the tangent structure of  $\mathbb{X}$  pointwise. Thus, for example, the category of arrows in a tangent category  $\mathbb{X}^2$  is again a tangent category.

For more examples and theory of tangent categories, see [8] and [2].

We now turn to vector fields and their associated bracket in this abstract setting.

**Definition 2.8.** For  $M$  an object of a tangent category  $(\mathbb{X}, \mathbb{T})$ , a **vector field on  $M$**  is a section of the projection  $p_M : TM \rightarrow M$ ; that is, a map  $x : M \rightarrow TM$  with  $x p_M = 1$ .

For two vector fields  $x$  and  $y$  on  $M$ , we will write  $x + y$  for the expression  $\langle x, y \rangle_+$ , and  $x - y$  for  $\langle x, y \rangle_-$ .

Now, for vector fields  $x$  and  $y$  on  $M$ , consider the following map:

$$xT(y) - yT(x)c : M \rightarrow T^2M.$$

One can show (see [2], lemma 3.13) that  $T(p)$  of this expression gives 0, so by the universality of the vertical lift, we get an associated unique map from  $M$  to  $T_2M$ , and then by composing with the first projection, an associated unique map from  $M \rightarrow TM$ , which we denote by  $[x, y]$ .

**Definition 2.9.** For vector fields  $x$  and  $y$  on an object  $M$  in a tangent category  $(\mathbb{X}, \mathbb{T})$  (with negatives), their **Lie bracket** is  $[x, y]$  as defined above.

Note that we need negation in order to be able to define this bracket. Accordingly, throughout the rest of the paper we assume we are working in a tangent category which has negatives.

This abstract definition generalizes definitions in the existing models: for the standard model, see [4], lemma 6.13; for synthetic differential geometry, see [8], page 6.

It is not difficult to prove the following properties of the bracket operation in this setting (see [2], theorem 3.17):

- $[x, y]$  is again a vector field on  $M$ .
- $[x_1 + x_2, y] = [x_1, y] + [x_2, y]$  and  $[x, y_1 + y_2] = [x, y_1] + [x, y_2]$ .
- $[x, y]_- = [y, x]$ .

The key property we are interested in, however, is the Jacobi identity:

$$[x, [y, z]] + [z, [x, y]] + [y, [z, x]] = 0.$$

This is crucial as without it one does not have a Lie bracket. As mentioned above, Rosický did not include a proof of this in his paper, but did provide to us an approximately 80 page handwritten manuscript containing a proof which assumed some additional pullbacks to be present in the tangent category. The goal in this paper is to prove this result more efficiently and without the use of additional limits.

### 3. Graphical language for tangent categories

The key to our simpler proof is the use of the graphical language of 2-categories. Graphical languages for monoidal categories have been extensively used (see [6] for an overview). The graphical language for a 2-category (or bicategory) is similar, but involves using regions for objects. Thus, in a 2-category, the objects are represented as regions, the arrows as strings, and the 2-cells as boxes connecting those strings.

In particular, we will be using this graphical language for the 2-category  $\mathbf{CAT}$  of categories, functors, and natural transformations. Thus, in our diagrams, regions represent categories, wires represent functors, and boxes represent natural transformations.

For the calculations we are interested in, most of the regions will be the chosen tangent category  $\mathbb{X}$ , while most of the wires will be the tangent functor  $T$ . However, we will also use the terminal category  $\mathbf{1}$ , as we need to handle vector fields. We can view an object  $M$  of  $\mathbb{X}$  as a functor  $\mathbf{1} \rightarrow \mathbb{X}$ , and then a vector field  $x$  on  $M$  can be viewed as a natural transformation  $M \rightarrow MT$ . Thus, in this graphical language, the vector field  $x$  will be represented by the diagram

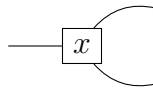

where we have omitted the labelling of the regions and wires:

- the top and middle-right regions are the category  $\mathbb{X}$  of the tangent category;
- the bottom region is  $\mathbf{1}$ , the terminal category;
- the left and bottom right wires are the object  $M$ , viewed as a functor  $\mathbf{1} \rightarrow \mathbb{X}$ ;
- the top right wire is the functor  $T : \mathbb{X} \rightarrow \mathbb{X}$ .

In general in any calculation involving vector fields, the left-most and bottom wires will always be  $M$ ; all other wires will be  $T$ .

We will represent  $\ell : T \rightarrow T^2$  by a splitting of wires, and  $c : T^2 \rightarrow T$  by a crossing of wires:

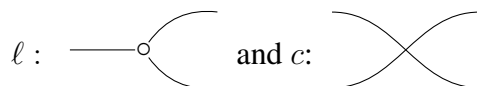

It is useful to view the coherence axioms for  $\ell$  and  $c$  in this graphical form.  $\ell c = \ell$  is



The axiom  $T(c)cT(c) = cT(c)c$  is

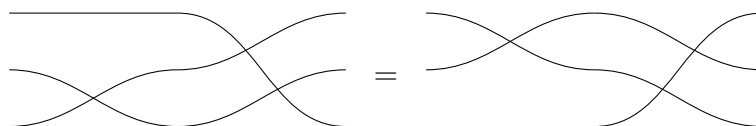

$\ell T(\ell) = \ell \ell$  is

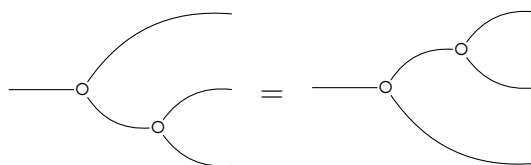

and  $\ell T(c)c = cT(\ell)$  is

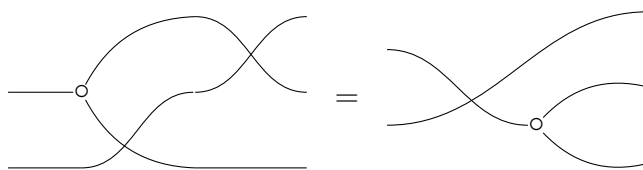

(Note that there is a similar version of this,  $c\ell = T(\ell)cT(c)$  simply by applying  $c$  and  $T(c)$  to both sides of the above equation).

Addition as directly defined is potentially problematic, as it involves a pullback, which is not easily represented graphically. However, we can view addition of vector fields in a different way: for vector fields  $x$  and  $y$ ,

$$x + y = xT(y)\langle Tp, p \rangle +$$



Moreover, the map  $\mu_1 := \langle Tp, p \rangle_+ : T^2M \rightarrow TM$  is a natural transformation<sup>2</sup>. Thus we have  $x + y = xT(y)\mu_1$ , and using  $\oplus$  for the natural transformation  $\mu_1$ , we can represent the addition of two vector fields  $x$  and  $y$  by the diagram

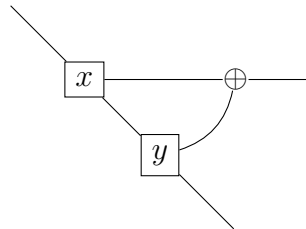

$\mu_1$  has the following coherence with  $\ell$  (the proof can be found in [2], proposition 3.8):

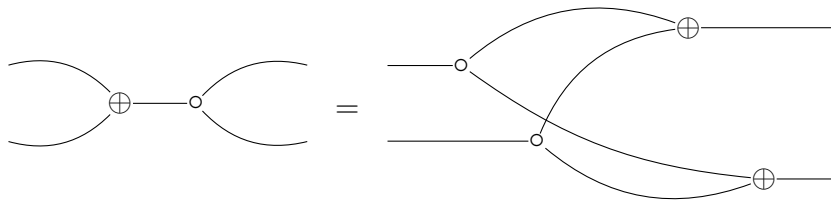

Negation will be represented by a dot; see below for an example.

We also need ways to deal with the Lie bracket and its universal property. Since the lift  $\ell$  is monic ([2], lemma 2.13), one way is to post-compose the bracket with  $\ell$ , giving the following equation:

$$[x, y]\ell = xT(y)T^2(x)T^3(y) - T(-)T(c)\mu_1T(\mu_1).$$

This is originally due to Rosický; a proof can be found in [2], lemma 3.16. This equation is then given graphically as

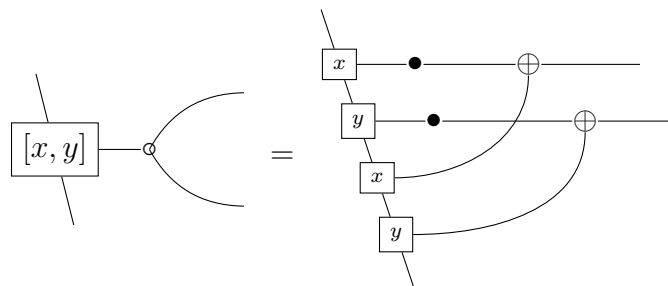

<sup>2</sup>In fact, it is the multiplication for a monad structure on  $T$ : see [2], section 3.2.

In fact, since  $\ell c = \ell$  and  $[x, y] = -[y, x]$ , there are many variants of this identity; we will return to this in the next section.

We also have the following result:

**Lemma 3.1.** *For vector fields  $a$  and  $b$*

$$aT(b)T(\ell)\ell T(c)\mu_1 = bT(a)T(\ell)\ell T(c)\mu_1 T(c).$$

*Proof.*

$$\begin{aligned} & aT(b)T(\ell)\ell T(c)\mu_1 \\ &= aT(b)T(\ell)\ell T(c)\langle T(p), p \rangle + \\ &= \langle aT(b)T(\ell)\ell T(c)T(p), aT(b)T(\ell)\ell T(c)p \rangle + \\ &= \langle aT(b)T(\ell)\ell T^2(p), aT(b)T(\ell)\ell pc \rangle + \\ &= \langle aT(b)T(\ell p)\ell, aT(b)T(\ell)\ell pc \rangle + \\ &= \langle aT(b)T(p0)\ell, aT(b)T(\ell)p0c \rangle + \\ &= \langle aT(0)\ell, b\ell T(0) \rangle + \\ &= \langle a\ell T^2(0), b\ell T(0) \rangle + \\ &= \langle a\ell T^2(0), b\ell T(0) \rangle + T(c)T(c) \\ &= \langle a\ell T^2(0)T(c), b\ell T(0)T(c) \rangle + T(c) \\ &= \langle a\ell T(0), b\ell T^2(0) \rangle + T(c) \\ &= \langle b\ell T^2(0), a\ell T(0) \rangle + T(c) \text{ (by symmetry)} \\ &= bT(a)T(\ell)\ell T(c)\mu_1 T(c) \end{aligned}$$

□

Graphically, this shows that “vector fields which are lifted to have a level in common commute”:

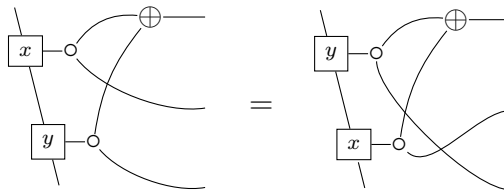

### 4. Proof of the Jacobi identity

This graphical calculus is very helpful when understanding how to manipulate complicated expressions, and helps suggest additional variants of identities. However, even it can get unwieldy when dealing with the large terms in the Jacobi identity. Thus, it is helpful to represent the terms that occur in the expansion of the Jacobi identity with a shorthand notation.

Typically, such terms consist of a sequence of vector fields, each of which is connected to one of three possible levels by addition, or two levels by a lift then a pair of additions. Thus, if a vector field  $a$  is connected to level  $i$  by addition, we write that term as  $a_i$ , and if that term is lifted then connected to levels  $i$  and  $j$  by addition, we write it as  $a_{ij}$ . We will also additionally simplify by writing the negation of a vector field  $a$  by  $\tilde{a}$ . As an example, in this notation the identity

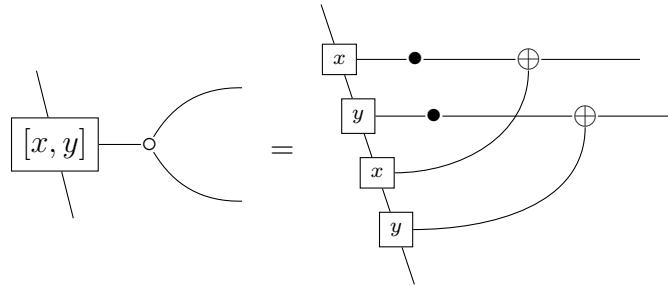

is written as

$$[x, y]_{12} = \tilde{x}_1 \tilde{y}_2 x_1 y_2.$$

This notation brings us closer to the notation used to prove the Jacobi identity in models of synthetic differential geometry: see the proofs in [5] and [7]. Indeed, some of the results we establish below are inspired by some of the calculations in those proofs.

**Lemma 4.1.** *For vector fields  $a, x, y, z$  in a tangent category, we have the following identities:*

1. *Bracket expansion:*

$$\begin{aligned} [x, y]_{12} &= \tilde{x}_1 \tilde{y}_2 x_1 y_2 = x_1 y_2 \tilde{x}_1 \tilde{y}_2 = y_1 \tilde{x}_2 \tilde{y}_1 x_2 = \tilde{y}_1 x_2 y_1 \tilde{x}_2 \\ &= \tilde{x}_2 \tilde{y}_1 x_2 y_1 = x_2 y_1 \tilde{x}_2 \tilde{y}_1 = y_2 \tilde{x}_1 \tilde{y}_2 x_1 = \tilde{y}_2 x_1 y_2 \tilde{x}_1. \end{aligned}$$

2. Two terms lifted to have a level in common commute:

$$x_{12}y_{13} = y_{13}x_{12} \text{ and } x_{12}y_{23} = y_{23}x_{12}.$$

3. Brackets commute with their constituents:

$$x_1[x, y]_{12} = [x, y]_{12}x_1 \text{ and } x_2[x, y] = [x, y]x_2$$

4.  $a_{12}z_3\tilde{a}_{12}\tilde{z}_3 = z_3\tilde{a}_{12}\tilde{z}_3a_{12}$ .

*Proof.* 1. As mentioned earlier, [2], lemma 3.16 proves the first equation. The fact that  $\ell c = \ell$  accounts for half of the forms. As  $\ell - T(-) = - - \ell = \ell$  we obtain the forms in which the negations have been flipped from the top two wires to the bottom two wires or from the outside wires to the inside wires. As  $[y, x]- = [x, y]$  we get the form in which the order of vector fields is flipped and the negation moved from top two to the inside (or outside) two wires.

2. The first version was established in lemma 3.1; the second version is similar.

3. Using 1,

$$x_1[x, y]_{12} = x_1\tilde{y}_2\tilde{x}_1y_2x_1 = [x, y]_{12}x_1.$$

The other identity is proved similarly.

4. We use 1 and the coherence of  $\ell$  with  $\oplus$ :

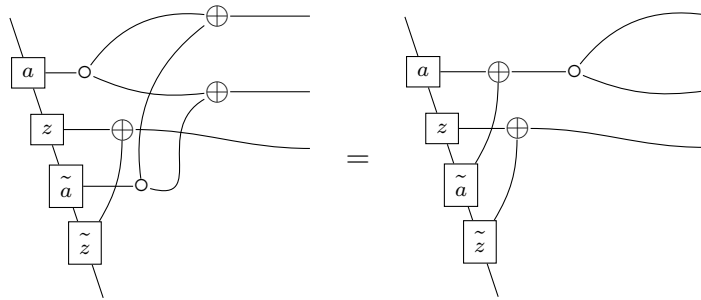

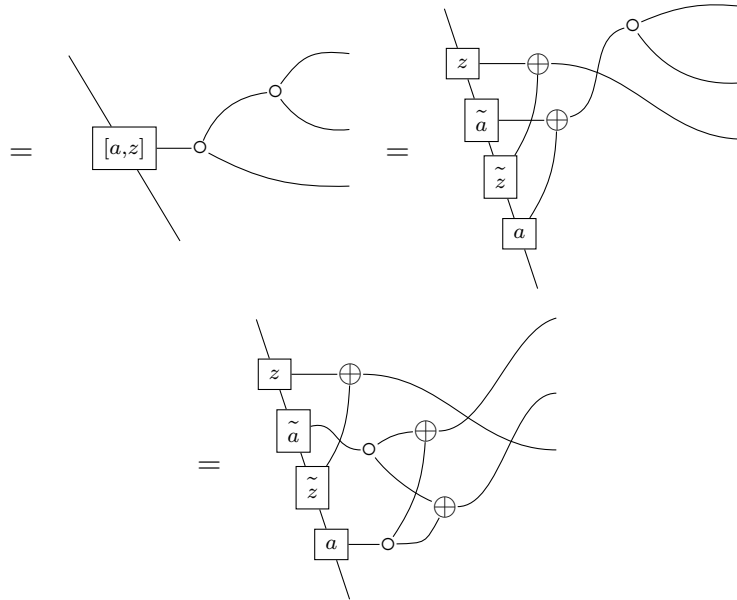

□

With these lemmas established, we can now give a relatively short proof of the Jacobi identity in a tangent category.

**Theorem 4.2.** (*Jacobi identity*) For vector fields  $x, y, z$  in a tangent category  $(\mathbb{X}, \mathbb{T})$ ,

$$[x, [y, z]] + [z, [x, y]] + [y, [z, x]] = 0.$$

*Proof.* We will actually prove a variant of the standard identity, namely

$$[[x, y], z] + [[y, z], x] + [[z, x], y] = 0.$$

First, recall that  $x + y$  can be represented as  $xT(y)\mu_1$ , so that the term above can be written in the graphical language as

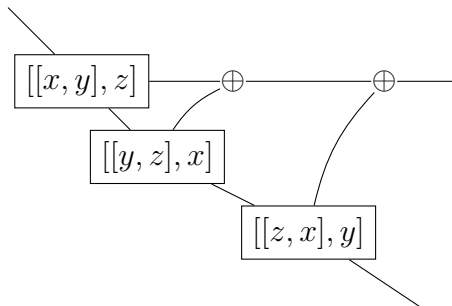

We then post-compose the term with  $\ell\ell$ . Using the coherence of  $\ell$  with  $\oplus$ , we then get the term

$$[[x, y], z]_{123} [[y, z], x]_{123} [[z, x], y]_{123}$$

We will now use the four parts of lemma 4.1 and negation to simplify the above term. In the proof below, a line underneath a term indicates that it is the term that will be modified next, the numerals indicate which part of lemma 4.1 is being used, and neg. indicates the use of negation, either to reduce a pair of terms or to add a pair of terms.

$$\begin{aligned}
 & \underline{[[x, y], z]_{123} [[y, z], x]_{123} [[z, x], y]_{123}} \\
 (1) &= [x, y]_{12} z_3 [y, x]_{12} \tilde{z}_3 [y, z]_{23} x_1 [z, y]_{23} \tilde{x}_1 [x, z]_{13} \tilde{y}_2 [z, x]_{13} y_2 \\
 (2,3) &= [x, y]_{12} [x, z]_{13} z_3 [y, x]_{12} \tilde{z}_3 [y, z]_{23} x_1 [z, y]_{23} \tilde{x}_1 \tilde{y}_2 [z, x]_{13} y_2 \\
 (1) &= [x, y]_{12} [x, z]_{13} z_3 [y, x]_{12} \tilde{z}_3 [y, z]_{23} x_1 [z, y]_{23} \tilde{x}_1 \tilde{y}_2 x_1 \tilde{z}_3 \tilde{x}_1 z_3 y_2 \\
 (\text{neg.}) &= [x, y]_{12} [x, z]_{13} z_3 [y, x]_{12} \tilde{z}_3 [y, z]_{23} x_1 [z, y]_{23} \tilde{x}_1 \tilde{y}_2 x_1 y_2 \tilde{y}_2 \tilde{z}_3 \tilde{x}_1 z_3 y_2 \\
 (1) &= [x, y]_{12} [x, z]_{13} z_3 [y, x]_{12} \tilde{z}_3 [y, z]_{23} x_1 [z, y]_{23} [x, y]_{12} \tilde{y}_2 \tilde{z}_3 \tilde{x}_1 z_3 y_2 \\
 (2,3) &= [x, y]_{12} [x, z]_{13} z_3 [y, x]_{12} \tilde{z}_3 [x, y]_{12} [y, z]_{23} x_1 [z, y]_{23} \tilde{y}_2 \tilde{z}_3 \tilde{x}_1 z_3 y_2 \\
 (1) &= [x, y]_{12} [x, z]_{13} z_3 [y, x]_{12} \tilde{z}_3 [x, y]_{12} [y, z]_{23} x_1 \tilde{z}_3 \tilde{y}_2 z_3 y_2 \tilde{y}_2 \tilde{z}_3 \tilde{x}_1 z_3 y_2 \\
 (\text{neg.}) &= [x, y]_{12} [x, z]_{13} z_3 [y, x]_{12} \tilde{z}_3 [x, y]_{12} [y, z]_{23} x_1 \tilde{z}_3 \tilde{y}_2 \tilde{x}_1 z_3 y_2 \\
 (2,3) &= [y, z]_{23} [x, y]_{12} [x, z]_{13} z_3 [y, x]_{12} \tilde{z}_3 [x, y]_{12} x_1 \tilde{z}_3 \tilde{y}_2 \tilde{x}_1 z_3 y_2 \\
 (4) &= [y, z]_{23} [x, y]_{12} [x, z]_{13} [y, x]_{12} \tilde{z}_3 [x, y]_{12} z_3 x_1 \tilde{z}_3 \tilde{y}_2 \tilde{x}_1 z_3 y_2 \\
 (\text{neg.}) &= [y, z]_{23} [x, y]_{12} [x, z]_{13} [y, x]_{12} \tilde{z}_3 [x, y]_{12} z_3 x_1 \tilde{z}_3 \tilde{x}_1 x_1 \tilde{y}_2 \tilde{x}_1 z_3 y_2 \\
 (1) &= [y, z]_{23} [x, y]_{12} [x, z]_{13} [y, x]_{12} \tilde{z}_3 [x, y]_{12} [z, x]_{13} x_1 \tilde{y}_2 \tilde{x}_1 z_3 y_2 \\
 (2,3) &= [y, z]_{23} [x, y]_{12} [x, z]_{13} [z, x]_{13} [y, x]_{12} \tilde{z}_3 [x, y]_{12} x_1 \tilde{y}_2 \tilde{x}_1 z_3 y_2 \\
 (\text{neg.}) &= [y, z]_{23} [x, y]_{12} [y, x]_{12} \tilde{z}_3 [x, y]_{12} x_1 \tilde{y}_2 \tilde{x}_1 z_3 y_2 \\
 (\text{neg.}) &= [y, z]_{23} \tilde{z}_3 [x, y]_{12} x_1 \tilde{y}_2 \tilde{x}_1 z_3 y_2 \\
 (\text{neg.}) &= [y, z]_{23} \tilde{z}_3 [x, y]_{12} x_1 \tilde{y}_2 \tilde{x}_1 y_2 \tilde{y}_2 z_3 y_2 \\
 (1) &= [y, z]_{23} \tilde{z}_3 [x, y]_{12} [y, x]_{12} \tilde{y}_2 z_3 y_2 \\
 (\text{neg.}) &= [y, z]_{23} \tilde{z}_3 \tilde{y}_2 z_3 y_2 \\
 (1) &= [y, z]_{23} [z, y]_{23} \\
 (\text{neg.}) &= 0_{123}
 \end{aligned}$$

Thus, since  $\ell$  is monic ([2], lemma 2.13), we have

$$[[x, y], z] + [[y, z], x] + [[z, x], y] = 0.$$

as required. □

## References

- [1] Blute, R., Cockett, R. and Seely, R. Cartesian differential categories. *Theory and Applications of Categories*, **22**, pg. 622–672, 2008.
- [2] Cockett, R. and Cruttwell, G. Differential structure, tangent structure, and SDG. *Applied Categorical Structures*, **22** (2), pg. 331–417, 2014.
- [3] Kóľár, I, Michor, P, and Slovák, J. *Natural operations in differential geometry*. Springer-Verlag, 1993.
- [4] Kriegl, A. and Michor, P. *The convenient setting of global analysis*. AMS Mathematical Surveys and monographs, vol. 53, 1997.
- [5] Lavendhomme, R. *Basic concepts of synthetic differential geometry*. Springer-Verlag, 1996.
- [6] Selinger, P. A survey of graphical languages for monoidal categories. In *New structures for physics*, (ed. Bob Coecke), Lectures notes in physics 813, pg. 289–355, 2011.
- [7] Moerdijk, I. and Reyes, G. *Models for Smooth Infinitesimal Analysis*, Springer, 1991.
- [8] Rosický, J. Abstract tangent functors. *Diagrammes*, 12, Exp. No. 3, 1984.

Robin Cockett  
 Computer Science Department  
 University of Calgary  
 Calgary, AB, Canada

robin@ucalgary.ca

and

Geoff Cruttwell  
Mathematics and Computer Science Department  
Mount Allison University  
Sackville, NB, Canada  
gcruttwell@mta.ca

Both authors gratefully acknowledge NSERC for support of this research through Discovery Grants.